



# ASSEMBLY MANUAL >

## *T R I M L I N E* **A9**



**RECORD SERIAL NUMBER**

*Elite Trimline A9 Treadmill*

Thank you for purchasing the **Elite Trimline A9 Treadmill**.

For over 30 years, Elite Fitness™ has been New Zealand's largest supplier of fitness equipment. Our aim and vision is to provide you Elite™ branded products, tested to the highest standard for quality and biomechanics at the best possible price.

Please read through this manual to familiarise yourself with the operation of your new **Elite Trimline A9 Treadmill**. Doing so will help to insure that you get the most out of your machine, enjoying safe and effective workouts ahead.

Even though we go to great effort to ensure the quality of each product we produce, occasional errors and or omissions do occur. In any event should you find this product to have either a defective or a missing part, please contact us for a replacement.

## **SERVICE & WARRANTY**

For service and warranty assistance please visit:

**[www.elitefitness.co.nz/service](http://www.elitefitness.co.nz/service)**

Online forms are available for Service, Warranty and Parts requests.

(09) 258 9067

### **Elite Fitness HQ**

28 Morrin Road,

St Johns

Auckland, New Zealand

[info@elitefitness.co.nz](mailto:info@elitefitness.co.nz)

0800 243 834

[www.elitefitness.co.nz](http://www.elitefitness.co.nz)

## **CONTENTS**

---

Important Safety Instructions	<b>3</b>	Care and Maintenance	<b>16</b>
Components of Treadmill	<b>5</b>	Maintenance Log	<b>18</b>
Assembly Instructions	<b>6</b>	Warranty Description	<b>19</b>
Moving and Storage Instructions	<b>11</b>	Warm-Up Exercises	<b>20</b>
User Instructions	<b>12</b>	Training Stages	<b>21</b>

# IMPORTANT SAFETY INSTRUCTIONS

---

The following definition applied to the word “WARNING” when used in this manual:



Used to call attention to POTENTIAL hazards that could result in personal injury.

## READ ALL INSTRUCTIONS BEFORE USING THE MACHINE

This product has been designed for **home use only**. Product liability and warranty conditions will not be applicable to products being subjected to professional use or products being used in a commercial environment. e.g Gym Centre, Retirement Centre, Home Based PT Studio and Physio.

This exercise machine is built for optimum safety. However, certain precautions apply whenever you operate a piece of exercise equipment. Be sure read the entire manual before you assemble or operate your machine. In particular, note the following safety precautions.

- Read all instructions in this manual before using this equipment.
- Use the machine only for its intended use as described in this manual.
- Inspect and tighten all the loose parts before this equipment is used.
- Keeps hands away from moving parts.
- Keep children and pets away from the machine at all time. DO NOT leave children unattended in the same room with the machine.
- Before using the machine to exercise, always do stretching exercises to properly warm up.
- Inspect the machine before each use; make sure all of the connections are tightly secured.
- Only one person at a time should use the machine.
- If the user experiences dizziness, nausea, chest pain, or any other abnormal symptoms, STOP the workout at once. **CONSULT A PHYSICIAN IMMEDIATELY.**
- Position the machine on a clear, levelled surface. DO NOT use the machine near water or outdoors.
- Always wear appropriate workout clothing when exercising. DO NOT wear robes or other clothing that could become caught in the machine. Sporting shoes are recommended when using the machine.
- Do not place any sharp object around the machine.
- Disabled persons should not use the machine without a qualified person or physician in attendance.
- Never operate the machine if the machine is not functioning properly.
- Only carry out training work on the equipment when it is in perfect working order. Only use original spare parts in the event of a repair.
- Do not use strong solvents for cleaning, and only use the tools supplied, or suitable ones of your own, for any repairs that may be required. Please dispose of the packaging and any parts that have to be replaced subsequently (all parts for the unit) at suitable collecting points or containers with a view to saving the environment.
- Not for therapeutic use.

**WARNING:** Before beginning any exercise programme, consult your physician. This is especially important for persons with pre-existing health problems. The seller assumes no responsibility for personal injury or property damage sustained by or through the use of this product.

**SERVICE HINTS:** The high quality standard of this product only will be kept if you, on a regular basis, check all screw connections and moving parts on proper fitting. Damaged parts need to be changed immediately. During the time of repair the product must not be used by anybody.

**IMPORTANT HINTS:**

- A) This product has been tested in accordance with the requirements of EN 957-1/A1, EN 957-5, standard, Class HA (HOME USE). The maximum load is limited to 150 kg.
- B) Parents should be aware of the risk factor of young children playing on fitness equipment unattended. Make sure that children are instructed properly in the use of the product and in the controlled execution of the different exercises. Misuse of the product could result in serious injury.

## PRODUCT SPECIFICATIONS

---

User Weight Capacity:	150 kg
Dimensions:	163 x 86.5 x 170 cm
Shipping Weight:	115 kg
Net Weight:	105 kg
Engine Power:	2 Motors, 1.25 CHP each
Inclined Slope:	15 Levels
Speed Range:	0 - 20 km/h
Bluetooth:	Trimline A9

---

# COMPONENTS OF TREADMILL

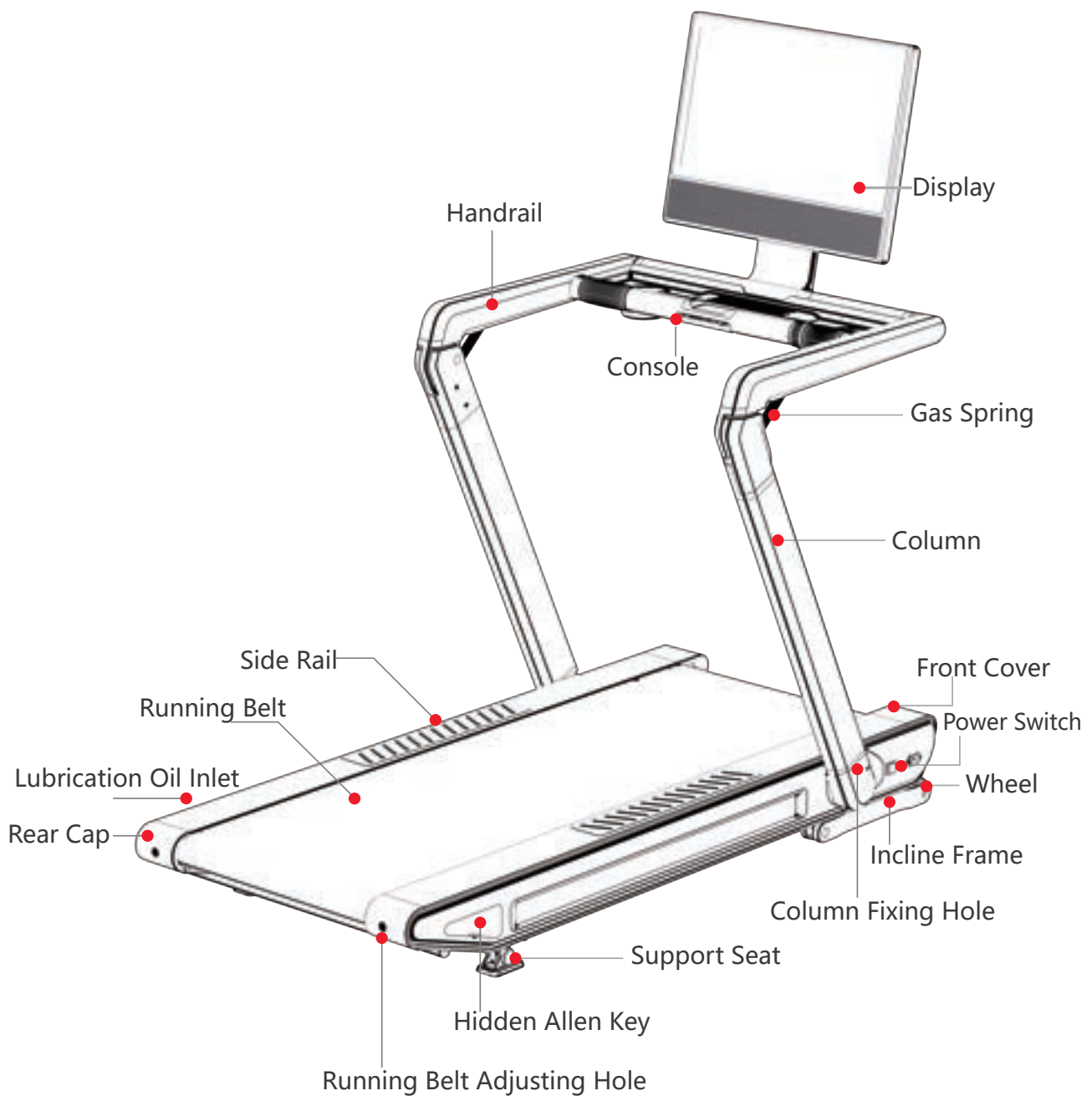

**Please Note:** Above is a list of the components of this treadmill. Please ensure all parts are included before you begin.

# ASSEMBLY INSTRUCTIONS

---

## Unfolding and Installation

**STEP 1:** Remove the plastic cover positioned under the right rear cap and take out the hidden allen wrench, see Figure 1.

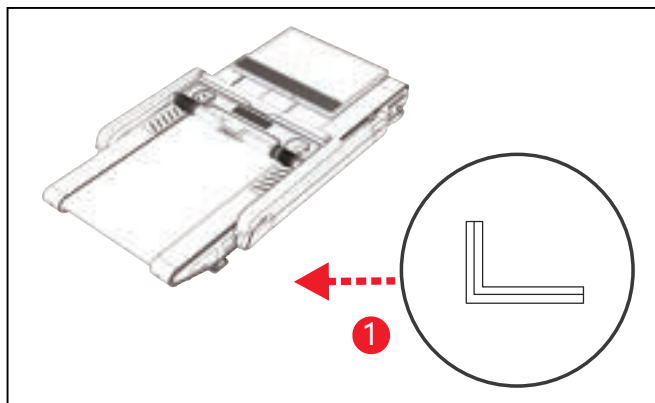

**STEP 2:** Lift the treadmill upwards to its reach capacity, see Figure 2.

**STEP 3:** Use the Allen wrench to tighten the treadmills holes clockwise until the panels on the treadmill are firmly fixed and stable, see Figure 3

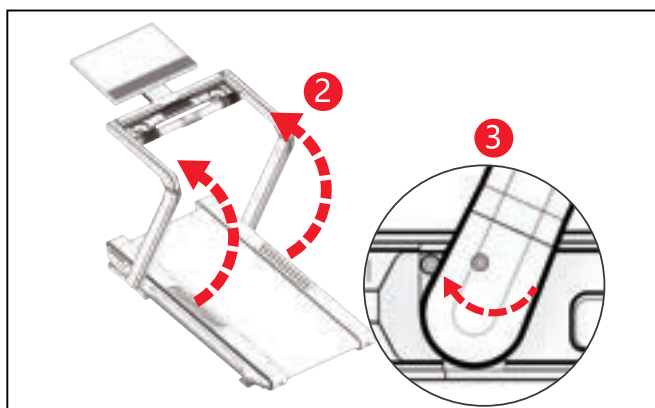

**STEP 4:** Hold the LED console display with both hands and adjust it upward to a suitable viewing angle, see Figure 4.

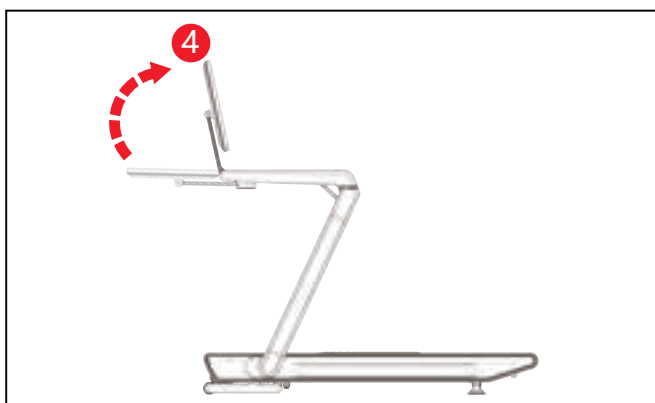

# ASSEMBLY INSTRUCTIONS

## Folding

**STEP 1:** Hold the display with both hands and adjust it downward to be parallel to the handrail, see Figure 1.

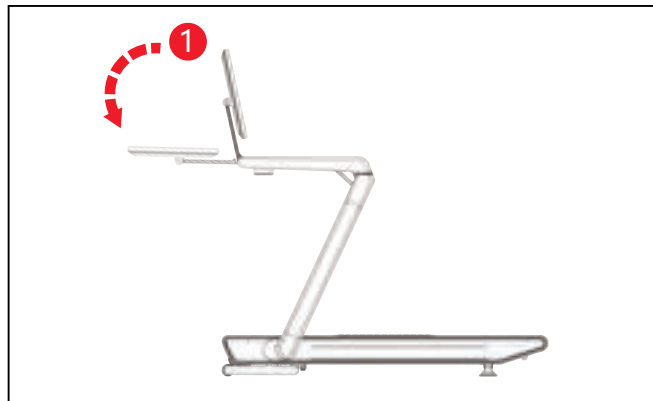

**STEP 2:** Loosen the panels on the left and right column counterclockwise with the Allen wrench, lay down the panels to be parallel to the side rail, see Figure 2.

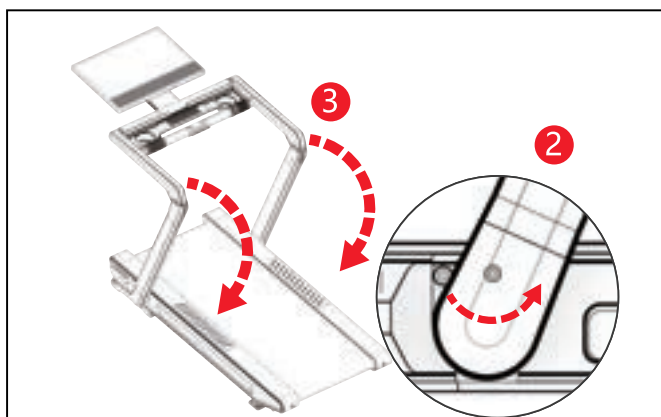

**STEP 3:** Place the Allen key in its original position, see Figure 3.

**STEP 4:** Use the Allen wrench to tighten the panels of the treadmill clockwise until both columns are secured, see Figure 4.

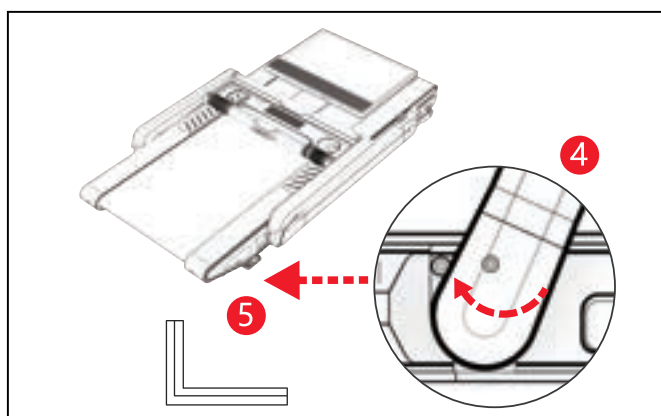

# ASSEMBLY INSTRUCTIONS

---



## CONGRATULATIONS

Assembly of your **Elite Trimline A9 Treadmill** is now complete! Be sure to fully inspect your machine before using it for the first time.

## **WARNING**

Failure to visually check and test and tech the assembly before use can cause damage to the **Elite Trimline A9 Treadmill** and serious injury to users and bystanders and can also compromise the effectiveness of your exercise program.

# MOVING AND STORAGE INSTRUCTIONS

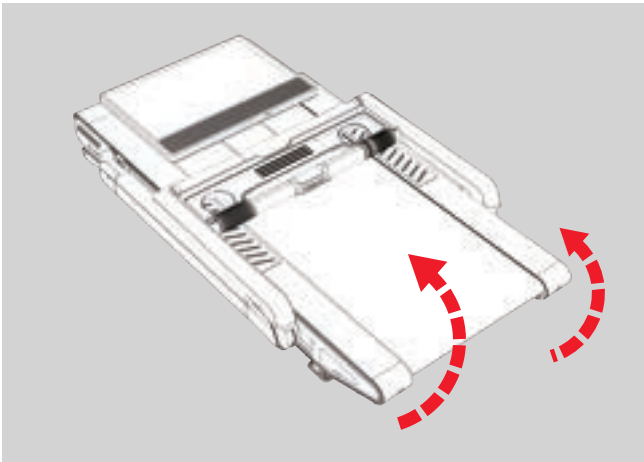

Pull out the horizontal bar under the running belt, hold the bar with both hands and lift the treadmill up.



There are 2 moving wheels under the motor cover, which can be used to move the treadmill to the desired position. Always hold the horizontal bar firmly when moving.

*Caution: please ensure the power cord cable has been disconnected from the treadmill before attempting to move it.*

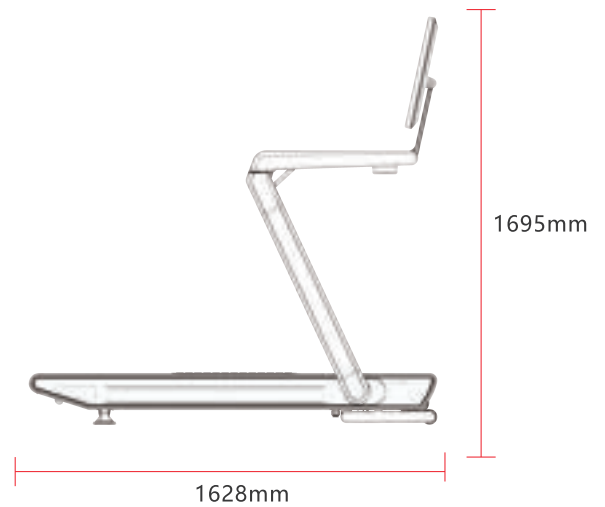
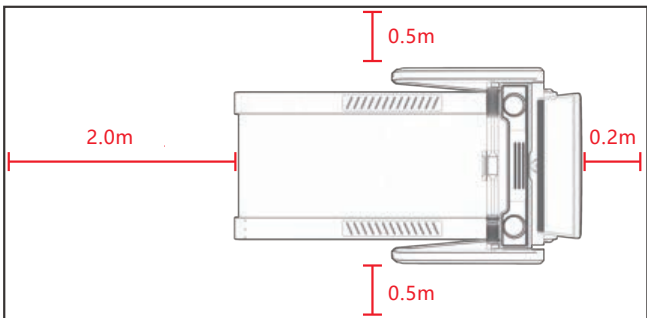

# USER INSTRUCTIONS

## CONSOLE DISPLAY

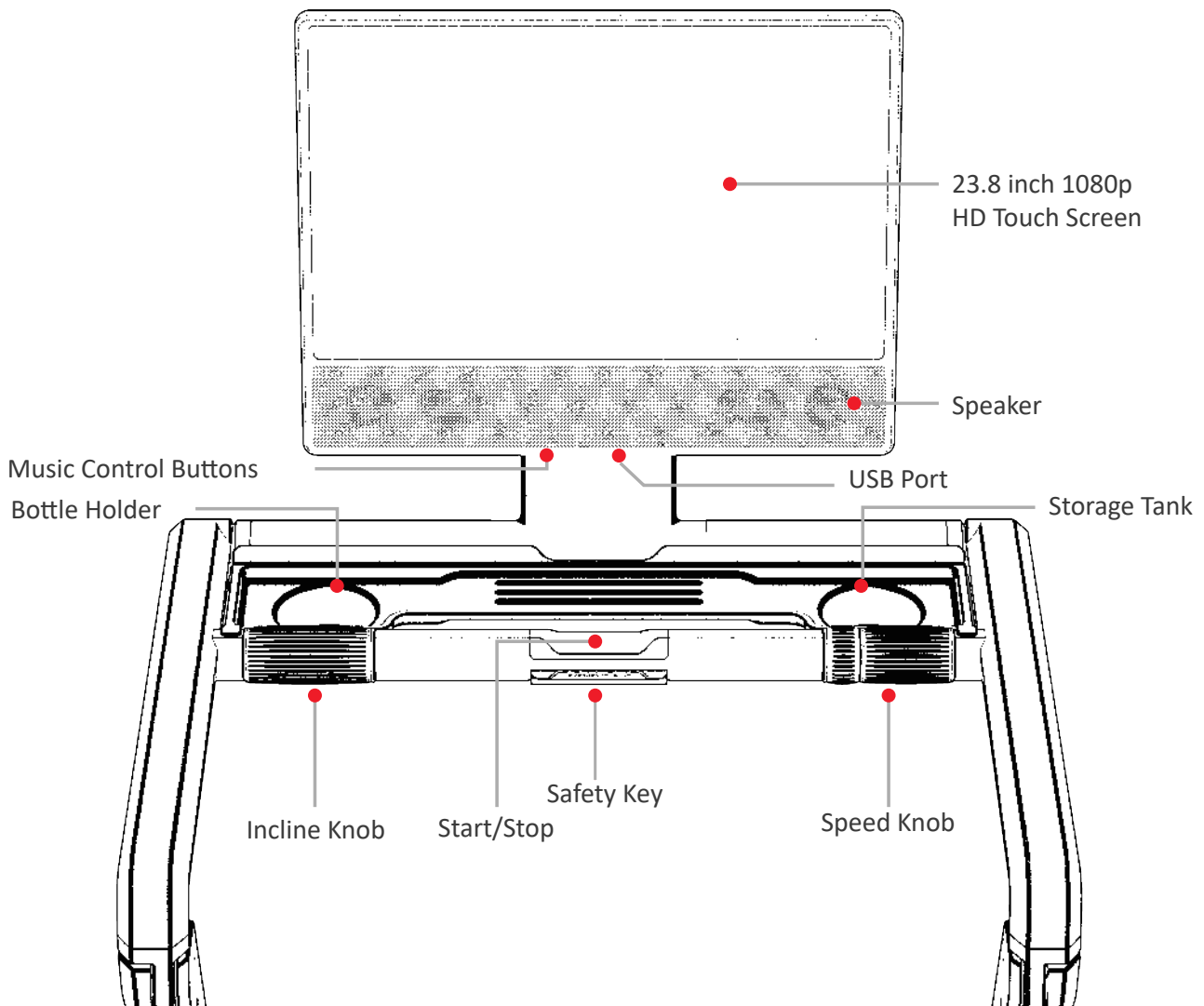

## Accessories



Silicone Oil

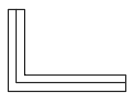

Allen Key



Manual

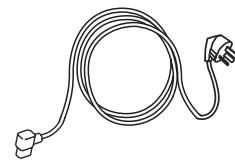

Power Cord

# USER INSTRUCTIONS

---

## MUSIC CONTROL BUTTONS

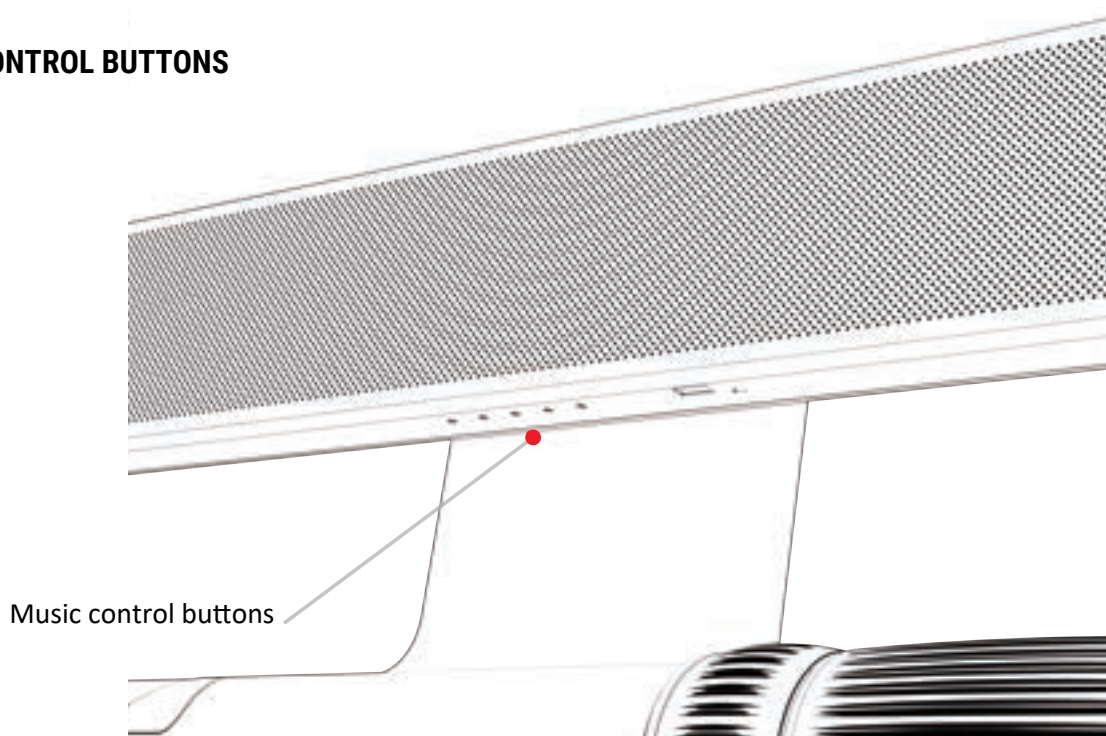

### “Previous Song” Button

- Press this button to play the previous song in the music list.



### “Next Song” Button

- Press this button to play the next song in the music list.



### “Play/Pause” Button

- Press this button to pause audio when it’s played.
- Press this button to play audio when it’s paused.



### “Volume-” Button

- Press this button to reduce the volume by 1 bar.
- Long press this button to continually decrease the volume.

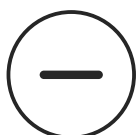

### “Volume+” Button

- Press this button to increase the volume by 1 bar.
- Long press this button to continually increase the volume.

# USER INSTRUCTIONS

---

## FUNCTION BUTTONS

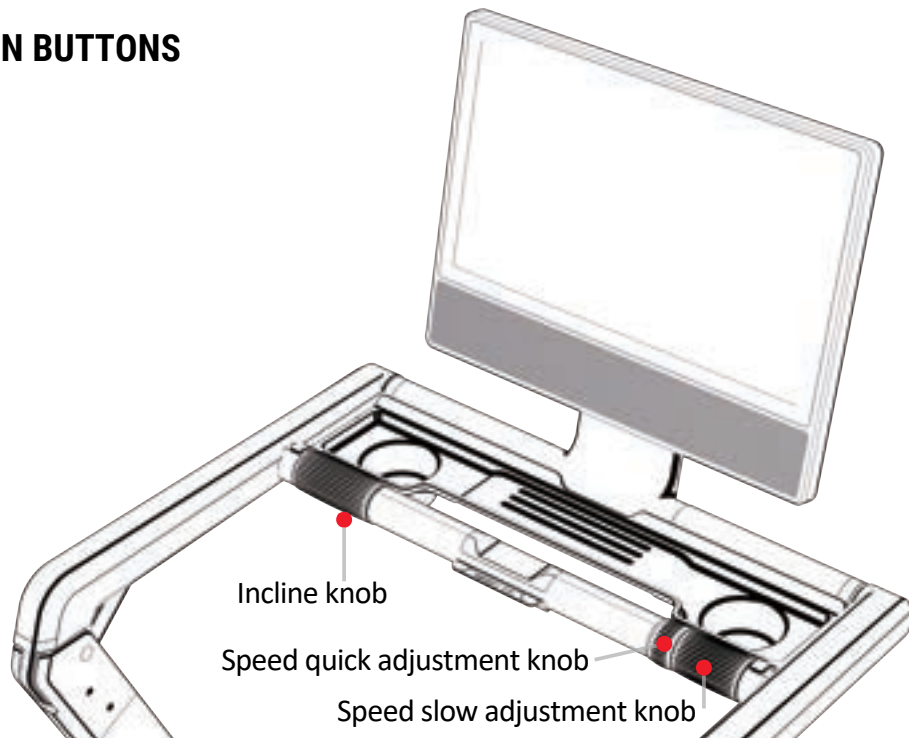

## INCLINE KNOB

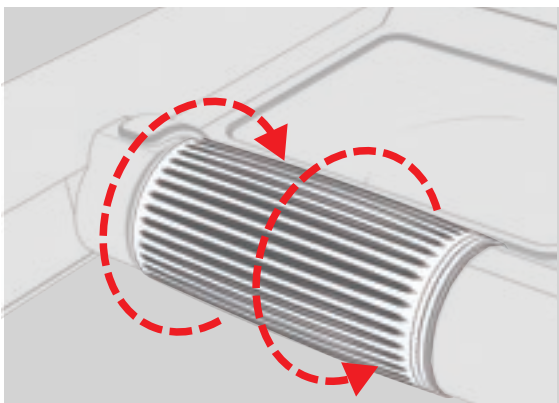

The knob on the left side of the front hand-rail is the incline adjustment key, scroll the knob upward to increase the incline angle and downward to decrease.  
Incline Range: 15 levels.

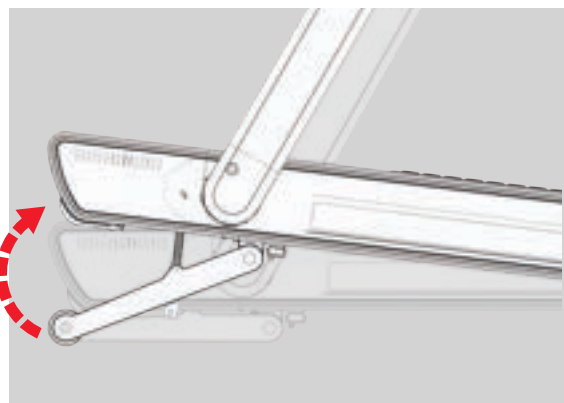

## ATTENTION!

The angle of the treadmill will change during the incline adjustment process, please keep your body balanced.

# USER INSTRUCTIONS

## SPEED KNOB

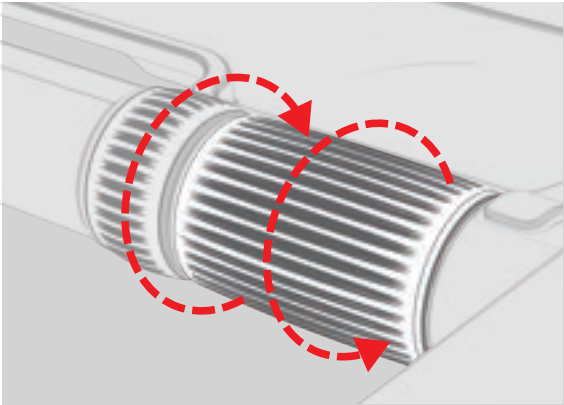

Speed slow adjustment :

The big knob on the right side of the front handrail is the speed slow adjustment key, scroll the knob upward to increase the speed in small increments and downward to decrease.

Speed range: 1-20KM/H.

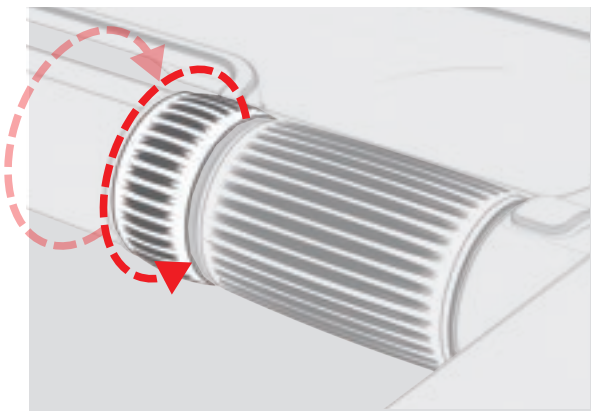

Speed quick adjustment :

The small knob on the right side of the front handrail is the speed quick adjustment key, scroll the knob upward to increase the speed in big increments and downward to decrease.

Speed range: 1-20KM/H.

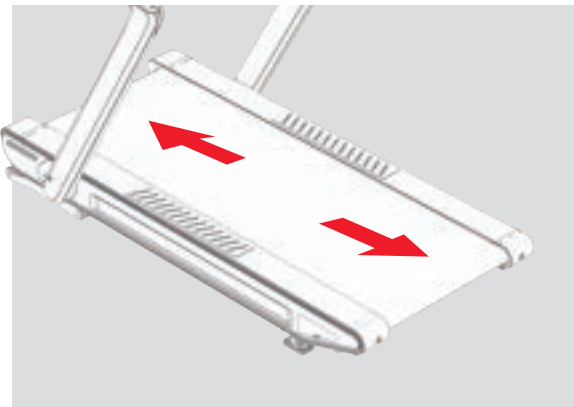

### ATTENTION!

The speed of the treadmill will change during the speed adjustment process, please keep your body balanced.

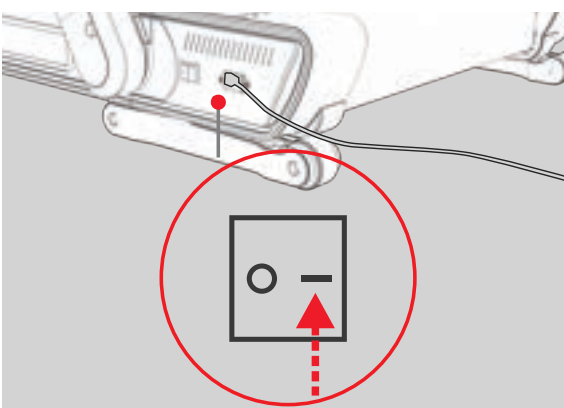

Power on the treadmill

- 1 The unit is equipped with a power switch that is located on the right side of the front cover.
- 2 Press the power switch to the on position - as shown in the Figure.

# USER INSTRUCTIONS

---

Turn on the treadmill power, the system will start incline self calibration, this takes around 10 seconds. Close the safety key and press START button. The treadmill will start to move at the lowest speed after 3 seconds countdown.

Adjust the speed with speed adjustment knob and adjust the incline with incline adjustment knob.

To stop the treadmill, reduce the speed gradually to the lowest, firmly hold the handrails and stand on the side rail on both sides.

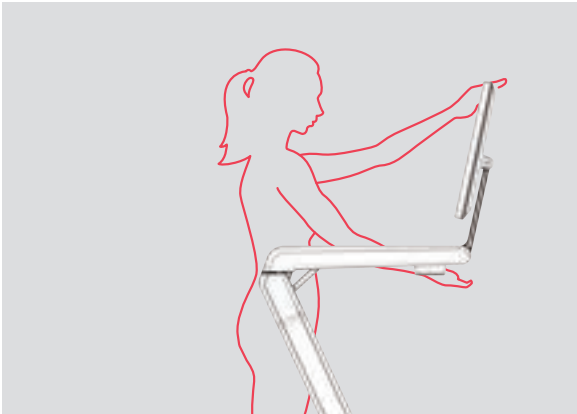

The display:

- Hold the display with both hands and adjust it to a suitable viewing angle.

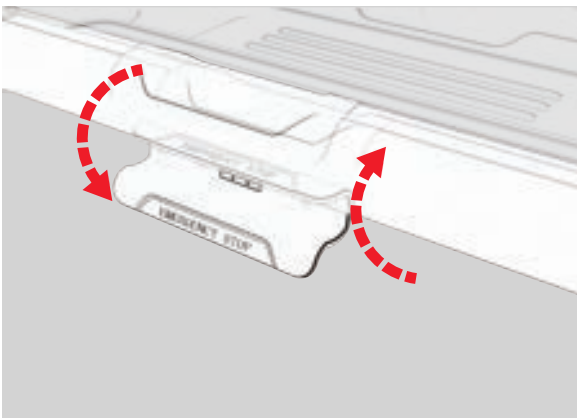

Safety key:

- Before using the treadmill, familiarize yourself with the emergency stop procedure. In case of emergency, pull off the safety key, and the machine will stop quickly.
- When the treadmill is in operation, if the safety key is disconnected, a "Warning" prompt will pop up on the screen, and the treadmill will come to a halt. To restart the treadmill, reset the safety key.



Side rail:

- The side rail is affixed on both sides of the running belt, allowing you to safely stand on either side of the treadmill during start-up or in case of an emergency.

# USER INSTRUCTIONS

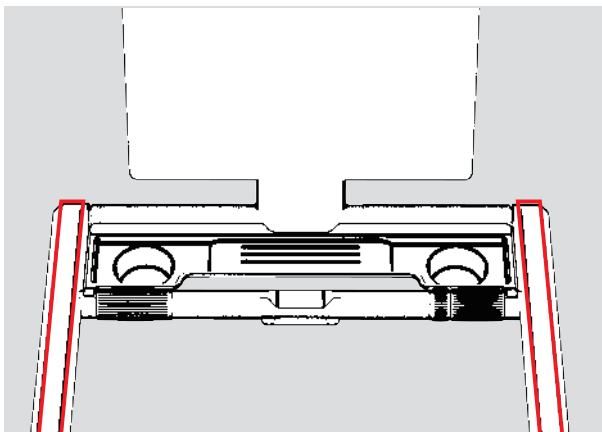

## Handrail

- Step on the edge of the treadmill from behind and use the handrails to keep your balance.
- When you touch the treadmill screen or operate the console, firmly hold the handrail with one hand.

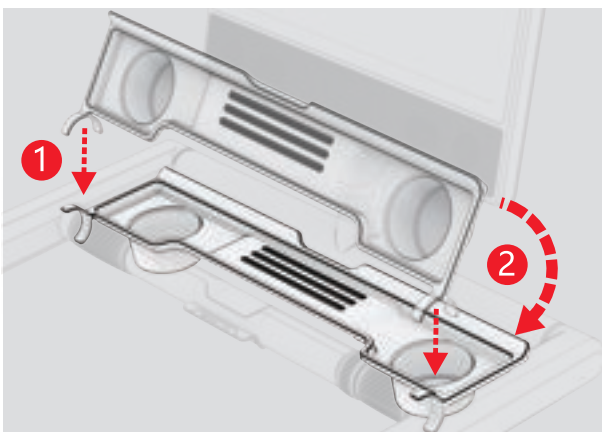

## Bottle holder/ Storage tank

- The bottle holder and storage tank are for users to place their personal belongings such as water bottle, mobile phone during exercising.
  - To use it, buckle the bottle holder onto front handrail and then lay it flat.
- See figure **1** **2**

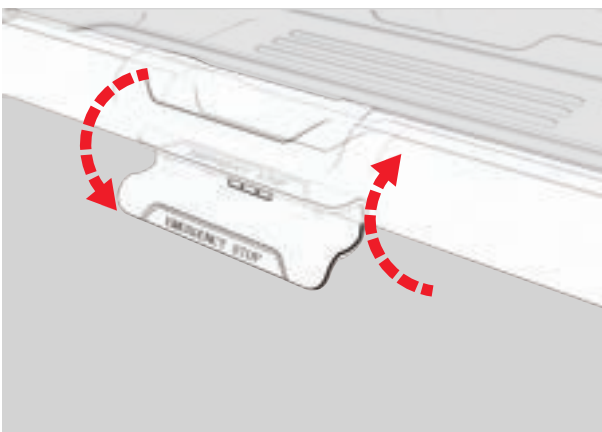

## Disconnect the safety key

- The treadmill cannot be started when the safety key is disconnected.
- To start running again, reset the safety key firstly.

## CARE AND MAINTENANCE

---

### **⚠ WARNING**

### **IMPORTANT INFORMATION**

Before cleaning or carrying out any maintenance on your treadmill, ensure the power is turned off and the power cord removed from the plug socket.

At least once a year, the motor cover on your treadmill should be removed and any dust or debris vacuumed up to maintain the smooth operation of the motor and drive system. Contact the Elite Fitness Service Department for further information on servicing your treadmill.

### **CLEANING**

General cleaning the unit will greatly prolong the treadmills working life.

Keep the treadmill clean by dusting regularly. Be sure to clean the exposed parts of the deck surface on both side of the walking belt and also the side rails. Make sure the soles of your shoes are clean , This reduces the build up of foreign material underneath the running belt. The top of the belt can be cleaned with a soapy, damp cloth. Be careful to keep liquid away from the electrical components and underneath the running belt.

Please ensure all sweat residue is wiped from any contact points or framework with a damp cloth using a suitable PH neutral detergent in water to avoid salt and corrosion deposits on your equipment. Failure or neglect to maintain and clean sweat residue from the treadmill frame may affect any frame warranty implied.

### **LUBRICATION**

This treadmill's running belt and deck are equipped with a pre-lubricated, low maintenance deck system. The belt/ deck friction may play a major role in the function and life of your treadmill, thus requiring periodic lubrication. We recommend a periodic inspection of the deck.



We recommend lubrication of the deck according to the following timetable

- Light user (less than 3 hours/ week) annually
- Medium user (3-5 hours/ week) every six months
- Heavy user (more than 5 hours/ week) every three months

*Treadmill lubricating oil can be purchased from your nearest Elite Fitness store or our Service Department.*

- In order to maintain and prolong the working life of your treadmill, we suggest you power off the treadmill for 10 minutes after every 2 hours of running use.
- A loose running belt may slip when you are running and may require a small adjustment; if the running belt is over tightened it can affect the performance of the motor and add extra wear to the rollers. For ideal tension, the running belt can be lifted 50-75mm from the central part of the running deck.

## CARE AND MAINTENANCE

Make sure the power cord is unplugged before cleaning or maintaining your treadmill. Open the oil filler upward, wait for 10-20 minutes

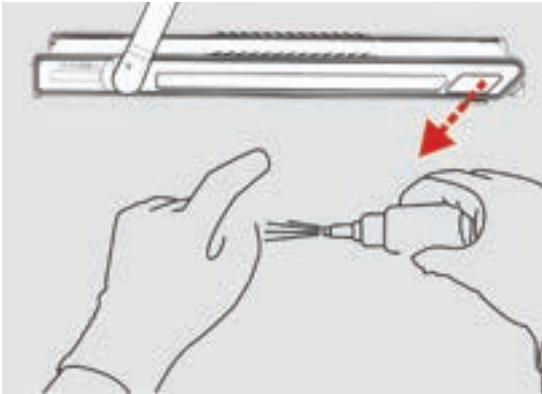

### Lubricating the Belt

1. Remove the plastic cover positioned under the left rear cap.
2. Turn the oil filler knob upward to open the lubrication oil inlet, pour the silicone oil (10 ml once) into the inlet, and turn the knob down to its original position to close the inlet.

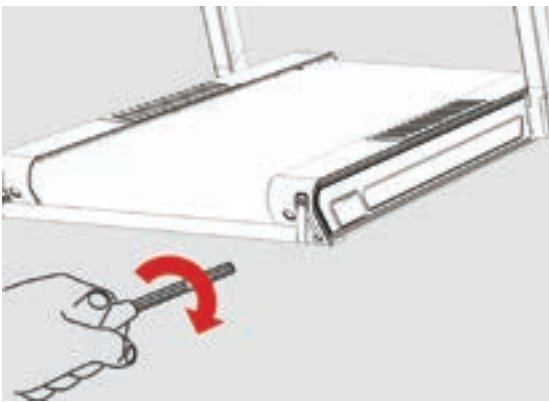

### The belt shifted to the right

If the belt has moved to the right, use the Allen wrench provided to turn the adjustment bolt on the right side clockwise by 1/4 turn, walk on the treadmill at a speed of 3km/h and observe whether the running belt is centered. If the belt is moved to the left, turn the adjusting bolt counterclockwise by 1/8 turn. Repeat the above actions until the belt is centered.

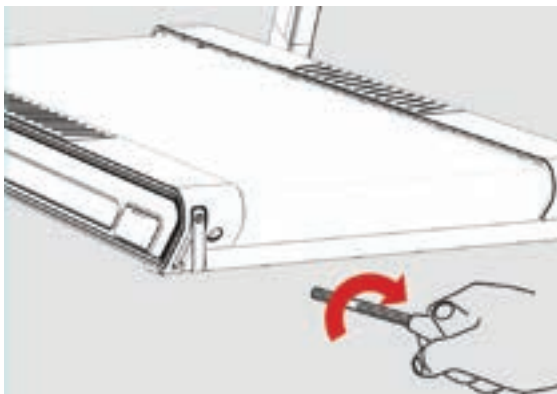

### The belt shifted to the left

If the belt has shifted to the left, use the Allen wrench provided to turn the adjustment bolt on the left side clockwise by 1/4 turn, walk on the treadmill at a speed of 3km/h and observe whether the running belt is centered. If the belt is moved to the right, turn the adjusting bolt counterclockwise by 1/8 turn. Repeat the above actions until the belt is centered.

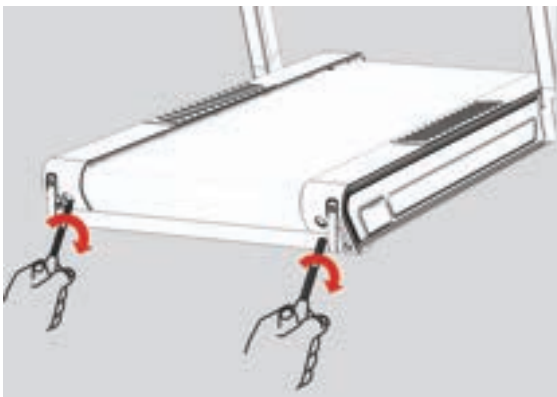

### Running belt is loose, drifting or slipping.

If the belt is slipping because it is too loose, use the Allen wrench provided to turn the adjustment bolt on both left and right side clockwise by 1/4 turn, walk on the treadmill at a speed of 3km/h and observe whether the running belt is tensed. Repeat, if necessary, until the belt remains tensed and centered during use.



# LIMITED WARRANTY

---

## WARRANTY RANGE

Damage in correct maintenance and normal operations (not factitious factors). Warranty card to the original purchaser, shall not be transferred.

## WARRANTY TIME

### HOME USE

- 10 Years Frame
- 10 Years Motor
- 2 Years Parts
- 1 Years Labour

ALL WARRANTIES BACK-TO-BASE\*

*\*Return to your nearest Elite Fitness Service Center.*

*The following conditions are not under warranty range:*

- A) As a result of abuse, neglect, accident, or unauthorized modification;
- B) The damage due to incorrect adjustment of the running belt and motor belt;

*The Treadmill should not be:*

- A) Plugged into a multi-board plug device. The treadmill requires a dedicated power circuit and should be plugged directly into the wall socket.
- B) Used with an extension cord any longer than 1.5m.
- C) Lubricated only with manufacturers approved silicone oil, do NOT use: WD40, CRC or any other lubricant. Consult Elite Fitness Service Department for advice or supply of the correct product.

## REPAIR AND MAINTENANCE SERVICE

Please contact our Elite Fitness Service Department at [EliteService@elitefitness.co.nz](mailto:EliteService@elitefitness.co.nz) or visit [www.elitefitness.co.nz](http://www.elitefitness.co.nz) for any service related issues or advice on preventative maintenance servicing procedures.

## WARM-UP EXERCISE

Warm up exercise is important in preparing the muscles for activity whilst minimising the risk of injury. You may choose to warm up with a light/brisk walking pace for 5-10 minutes before stopping and performing some simple stretches. (As shown in the pictures below)

— **Hamstring Stretch (Standing)**

Keep your knees slightly bent and slowly lean forward, back and shoulders relaxed, reaching towards your toes. You should feel the tension and slight discomfort in your hamstring muscles. Hold for 15-20 seconds. Repeat 2-3 times.

— **Hamstrings Stretches (Seated)**

Sitting on the floor preferably on a mat, put one leg straight, the other inward and close to the inside of the straight leg. Lean forward from the hips, reaching towards your toes. Hold for 10-15 seconds, and relax. Repeat 3 times for each leg (See picture 2).

— **Crus and Feet Tendon Stretches**

Standing with two hands on the wall or tree, one leg behind. Keeping your legs straight and the heel on the ground, lean forward towards the wall or tree. Hold for 10-15 seconds, and relax. Repeat 3 times for each leg (See picture 3).

— **Quadriceps Stretches**

Keeping your balance with your left hand holding onto a wall or stationery fixture, grasp your right foot with your right hand and stretch your right heel toward your buttocks slowly, until you feel the stretch in the front of your thigh. Hold for 10-15 seconds, and relax. Repeat 3 times for each leg (See picture 4).

— **Sartorius (Inner Muscles of the Thigh) Muscle Stretches**

Sitting down with the soles of your feet or shoes together and your knees positioned outward. Pull your feet towards your groin until you can feel the stretch. Hold for 10-15 seconds, and relax. Repeat 3 times (See picture 5).

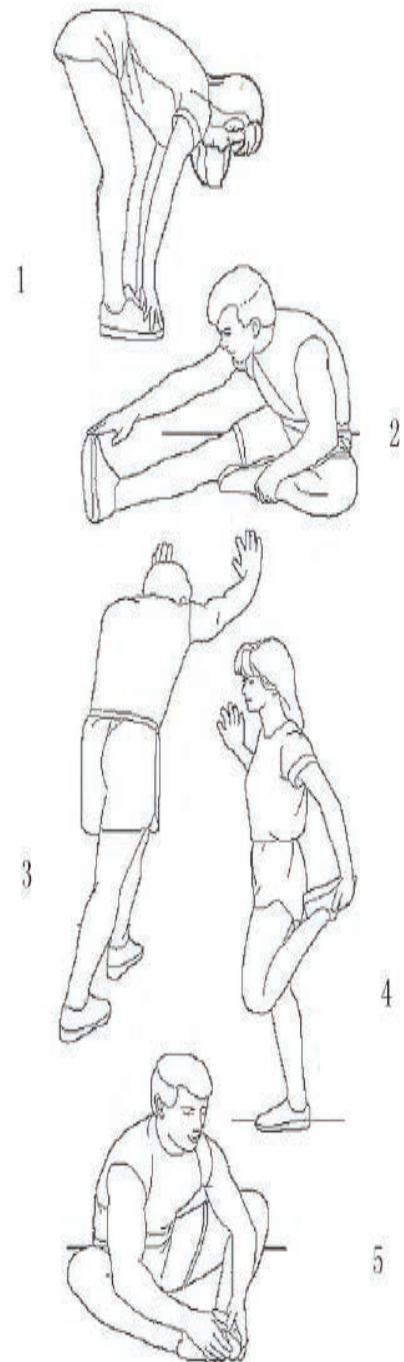

# TRAINING STAGES

		Exercise Zone									
		AGE									
Beats Per Minute	100%	200	195	190	185	180	175	170	165	155	150
	<b>VO2 Max (Maximum Effort)</b>										
	90%	180	176	171	167	162	158	153	149	140	135
	<b>Anaerobic (Hardcore Training)</b>										
	80%	160	156	152	148	144	140	136	132	124	120
	<b>Aerobic (Cardio Training/Endurance)</b>										
	70%	140	137	133	130	126	123	119	116	109	105
	<b>Weight Control (Fitness/Fat Burn)</b>										
	60%	120	117	114	111	108	105	102	99	93	90
	<b>Moderate Activity (Maintenance/Warm up)</b>										
50%	100	98	95	93	90	88	85	83	78	75	

Cardiovascular training plays an important part in maintaining a healthy heart and lung function, so it's no surprise we should be paying attention to how quickly our heart beats during exercise. The chart above outlines a range of heart rate training zones determined by the individual's age and workout goals to ensure you train safely and effectively.

Heart Rate can be measured by using the radial (wrist) or carotid (neck) pulse using your index and middle fingers, counting the beats for 10 seconds and multiplying by 6. Alternatively, the use of a Wireless Telemetry Heart Rate strap and watch will give you an accurate Beats Per Minute (BPM) reading.

$220 - \text{AGE} = \text{TMHR}$  (Theoretical Maximum Heart Rate)

$\text{TMHR} \times 85\% = \text{(Upper Training Limit) BPM}$

$\text{TMHR} \times 65\% = \text{(Lower Training Limit) BPM}$

Note: Contact heart rate may provide inaccurate readings and is designed only as a guide

Example:  $220 - 39 = 181 \text{ BPM}$

$181 \times 85\% (0.85) = 154 \text{ BPM}$  (Upper Training Limit)

$181 \times 65\% (0.65) = 118 \text{ BPM}$  (Lower Training Limit)





For more information about our Elite exercise equipment or other brands that we stock for your home, visit [www.elitefitness.co.nz](http://www.elitefitness.co.nz)

Copyright © 2023 Elite Fitness

Elite Fitness, 28 Morrin Road, St Johns, Auckland, New Zealand,  
0800 243 834, [www.elitefitness.co.nz](http://www.elitefitness.co.nz)

Keep up to date with the latest products, competitions and equipment, follow us on our social media sites.



[@EliteFitnessNZ](#)

[@EliteFitnessTV](#)